

# TB6600 Stepper Motor Driver SKU: DRI0043

## Contents

- 1 Introduction
- 2 Features
- 3 Specification
- 4 Quick Start
  - 4.1 Rquirements
  - 4.2 Connection Diagram
  - 4.3 Sample Code
  - 4.4 Result
  - 4.5 Comments
- 5 FAQ
- 6 More Documents

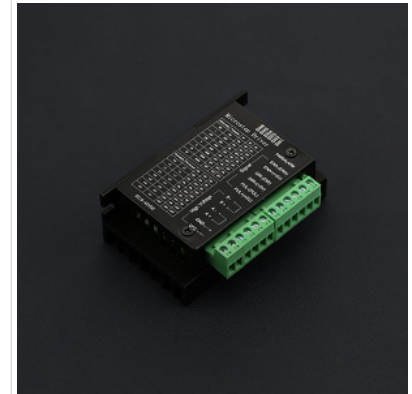

(<https://www.dfrobot.com/product-1547.html>)

TB6600 Stepper Motor Driver

(<https://www.dfrobot.com/product-1547.html>)

## Introduction

TB6600 arduino Stepper Motor Driver (<https://www.dfrobot.com/product-1547.html>) is an easy-to-use professional stepper motor driver (<https://www.dfrobot.com/category-106.html>), which could control a two-phase stepping motor. It is compatible with Arduino and other microcontrollers that can output a 5V digital pulse signal. TB6600 arduino stepper motor driver (<https://www.dfrobot.com/category-106.html>) has a wide range power input, 9~42VDC power supply. And it is able to output 4A peak current, which is enough for the most of stepper motors.

The stepper driver supports speed and direction control. You can set its micro step and output current with 6 DIP switch. There are 7 kinds of micro steps (1, 2 / A, 2 / B, 4, 8, 16, 32) and 8 kinds of current control (0.5A, 1A, 1.5A, 2A, 2.5A, 2.8A, 3.0A, 3.5A) in all. And all signal terminals adopt high-speed optocoupler isolation, enhancing its anti-high-frequency interference ability.

As a professional device, it is able to drive 57, 42-type two-phase, four-phase, hybrid stepper motor.

**Note: this is a upgrade version of TB6600 Stepper Motor Driver.**

## Features

- Support 8 kinds of current control
- Support 7 kinds of micro steps adjustable
- The interface adopts high-speed optocoupler isolation
- Automatic semi-flow to reduce heat
- Large area heat sink
- Anti-high-frequency interference ability
- Input anti-reverse protection
- Overheat, over current and short circuit protection

## Specification

- Input Current: 0~5A
- Output Current:0.5~4.0A
- Power (MAX): 160W
- Micro Step: 1, 2/A, 2/B, 4, 8, 16, 32
- Temperature: -10~45°C
- Humidity: No Condensation
- Weight: 0.2 kg
- Dimension: 96 \* 71 \* 37 mm

## Quick Start

In this section, we'll show you how to use TB6600 arduino motor driver quickly. More detail could be found on the User Guide ([https://github.com/Arduinolib/TB6600\\_Stepper\\_Motor\\_Driver/raw/master/TB6600%20User%20Guide%20V1.2.pdf](https://github.com/Arduinolib/TB6600_Stepper_Motor_Driver/raw/master/TB6600%20User%20Guide%20V1.2.pdf)).

## Rquirements

- **Hardware**
  - 1 x DFRduino UNO R3 (<https://www.dfrobot.com/product-838.html>)
  - 1 x TB6600 Stepper Motor Driver (<https://www.dfrobot.com/product-1547.html>)
  - 1 x Stepper motor (<https://www.dfrobot.com/product-1082.html>)
- **Software**
  - Arduino IDE Download Arduino IDE (<https://www.arduino.cc/en/Main/Software>)

## Connection Diagram

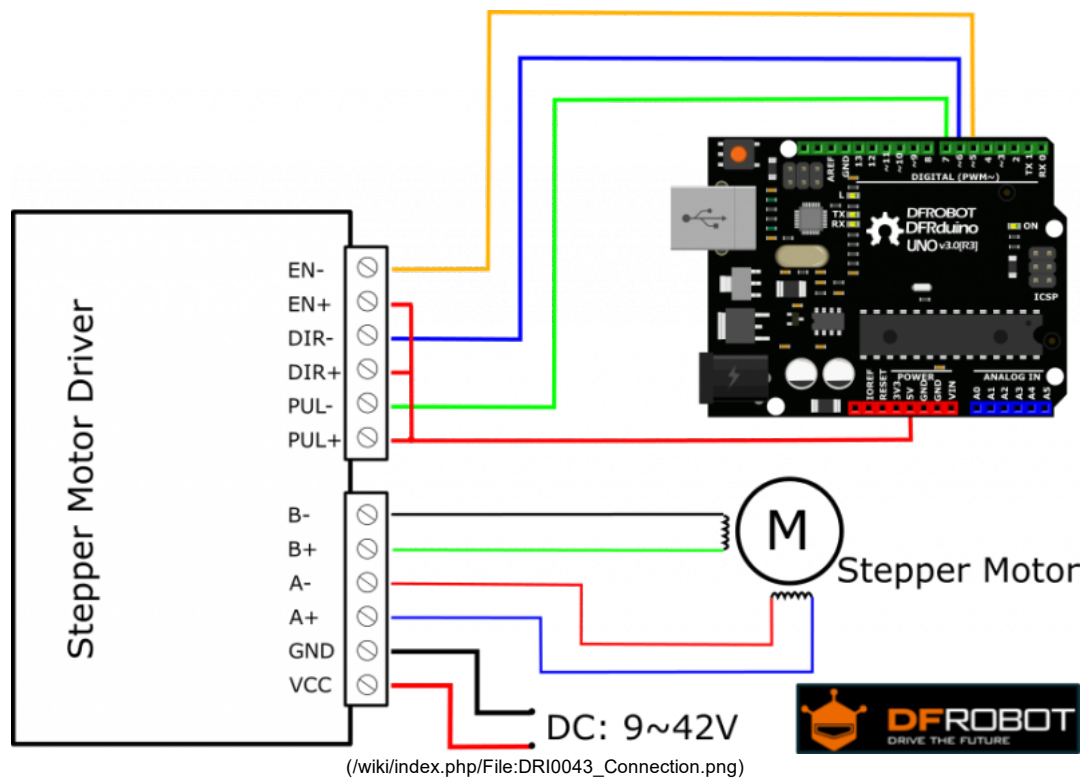

1. In this tutorial, we'll use a bipolar stepper motor, 1.8 step angle, 1.7A
2. Set current: 1.7A
3. Set Micro Step: 32
4. Connect a 9~42V DC power supply

Up: OFF; Down: "ON"

## Sample Code

```
int PUL=7; //define Pulse pin
int DIR=6; //define Direction pin
int ENA=5; //define Enable Pin
void setup() {
  pinMode (PUL, OUTPUT);
  pinMode (DIR, OUTPUT);
  pinMode (ENA, OUTPUT);
}

void loop() {
  for (int i=0; i<6400; i++) //Forward 5000 steps
  {
    digitalWrite(DIR,LOW);
    digitalWrite(ENA,HIGH);
    digitalWrite(PUL,HIGH);
    delayMicroseconds(50);
    digitalWrite(PUL,LOW);
    delayMicroseconds(50);
  }
  for (int i=0; i<6400; i++) //Backward 5000 steps
  {
    digitalWrite(DIR,HIGH);
    digitalWrite(ENA,HIGH);
    digitalWrite(PUL,HIGH);
    delayMicroseconds(50);
    digitalWrite(PUL,LOW);
    delayMicroseconds(50);
  }
}
```

## Result

The stepper motor rotates 6400 steps (a cycle), and reverses 6400 steps (a cycle).

## Comments

- When "EN" is Low, the motor is in a free states (Off-line mode). In this mode, you can adjust the motor shaft position manually; when "EN" is High (Vacant), the motor will be in an automatic control mode.
- "Direction" is the motor direction signal pin,
- "PULSE" is the motor pulse signal pin. Once the driver get a pulse, the motor move a step.

## FAQ

For any questions, advice or cool ideas to share, please visit the **DFRobot Forum** (<http://www.dfrobot.com/forum/>).

## More Documents

User Guide V1.2 ([https://github.com/Arduinolib/TB6600\\_Stepper\\_Motor\\_Driver/raw/master/TB6600%20User%20Guide%20V1.2.pdf](https://github.com/Arduinolib/TB6600_Stepper_Motor_Driver/raw/master/TB6600%20User%20Guide%20V1.2.pdf))

 (<http://www.dfrobot.com/>) Shopping from [TB6600 Arduino Stepper Motor Driver](https://www.dfrobot.com/product-1547.html) (<https://www.dfrobot.com/product-1547.html>)

**DFRobot Distributor.** (<http://www.dfrobot.com/index.php?route=information/distributorslogo>)

Category: DFRobot (<https://www.dfrobot.com/>)> Sensors &Modules (<https://www.dfrobot.com/category-156.html>) > **Stepper Motor Drivers** (<https://www.dfrobot.com/category-106.html>)

This page was last modified on 31 May 2017, at 06:26.

Content is available under GNU Free Documentation License 1.3 or later (<https://www.gnu.org/copyleft/fdl.html>) unless otherwise noted.



(<https://www.gnu.org/copyleft/fdl.html>)



(<http://www.mediawiki.org/>)